



vtech

For more support information

Quick start guide
(Canada version)



TECHNICAL SPECIFICATIONS

Frequency control	Crystal controlled PLL synthesizer
Transmit frequency	Baby unit: 2405 - 2475 MHz Parent unit: 2405 - 2475 MHz
Channels	32
LCD	2.8" Color LCD (QVGA 320x240 pixel)
Nominal effective range	Maximum power allowed by FCC and IC. Actual operating range may vary according to environmental conditions at the time of use.
Power requirements	Parent unit: 3.6V 2600mAh, 9.36Wh Li-ion battery Baby unit power adapter: Output: 6V DC @ 400mA Parent unit power adapter: Output: 5V DC @ 1A



Specifications are subject to change without notice.
© 2024 VTech Communications, Inc. All rights reserved.
03/24_VM819-X_QSG_CA_V1

IMPORTANT SAFETY INSTRUCTIONS

The applied nameplate is located at the bottom of the baby unit base. When in use, basic safety precautions should always be followed to reduce the risk of fire, electric shock and injury, including the following:

- Follow all warnings and instructions marked on the product.
- Adult setup is required.
- CAUTION:** Do not install the baby unit at a height above 6.5 feet (2 meters).
- This product is intended as an aid. It is not a substitute for responsible and proper adult supervision and should not be used as such.
- This product is not intended for use as a medical monitor.
- Do not use this product near water, for example, near to a bath, sink, swimming pool or shower.
- CAUTION:** Use only the internally, non-user replaceable battery fitted to the parent unit. There may be a risk of explosion if a wrong type of battery is used for the parent unit. The battery cannot be subjected to high or low extreme temperature and low air pressure at high altitude during use, storage or transportation. Disposal of batteries in fire or a hot oven, mechanically crushing or cutting the battery can result in an explosion. Subjecting products or batteries to an extremely high temperature environment can result in explosion or leakage of flammable liquids, or gas. Products or batteries subjected to extremely low air pressures may result in explosion or leakage of flammable liquids, or gas. Dispose of used batteries according to the information in **The RBRC seal**.
- Use only the power adapters supplied with this product. Incorrect power adapter polarity or voltage can seriously damage the product.

Power adapter information:
Parent unit output: 5V DC 1A
VTech Telecommunications Ltd.
Model: VT05EUS03100
Baby unit output: 6V DC 400mA
VTech Telecommunications Ltd.
Model: VT05EUS06040

Rechargeable battery information:
Zhuohai Great Power Energy Ltd.
Li-ion battery, 3.6V 2600mAh, 9.36Wh;
Model: ICR18650-2.6Ah-3.6V-351P

- The power adapter is intended to be correctly oriented in a vertical or floor mount position. The prongs are not designed to hold the plug in place if it is plugged into a ceiling, under-the-table or cabinet outlet.
- For pluggable equipment, the socket-outlet (power adapter) should be installed near the equipment and should be easily accessible.
- Unplug this product from the wall outlet before cleaning. Do not use liquid or aerosol cleaners. Use a damp cloth for cleaning.
- Do not modify the power adaptors or replace with other third-party adaptors.
- Do not allow anything to rest on the power cords. Do not install this product where the cords may be walked on or damaged.
- The product should only be operated from a power source indicated on the power adaptor label or marking. If you are unsure of the type of power supply in your home, consult your dealer or electricity supply provider.
- Do not overload wall outlets or use an extension cord.
- Do not place this product on an unstable table, shelf, stand or other unstable surfaces.
- This product should not be placed in any area where proper ventilation is not provided. Any slots or openings in the back or bottom of this product are provided for ventilation. To protect from overheating, openings must not be blocked by placing the product on a soft surface such as a bed, sofa or rug. This product should never be placed near or over a radiator or heat source.
- Never insert any objects through any apertures or slots in the

product as this can be dangerous and cause damage to the battery or other internal parts. Never spill any liquids on the product.

- To reduce the risk of electric shock, do not disassemble this product, but take it to an authorized service facility. Disassembling or removing parts of the product other than battery replacement via a battery door (if applicable) may expose dangerous voltages or other risks.
- You should test the sound reception every time you turn on the units or move one of the components.
- Periodically examine all components for damage.
- There is a very low risk of privacy loss when using certain electronic devices, such as baby monitors, cordless telephones, etc. To protect your privacy, make sure the product has never been used before purchase, reset the baby monitor periodically by powering off and then powering on the units, and power off the baby monitor if you are not intending to use it for some time.
- Children should be supervised to ensure that they do not play with the product.
- The small parts of this monitor can be swallowed by babies or small children. Keep these parts out of reach of children.
- The product is not intended for use by persons (including children) without adequate supervision or mental capabilities, or lack of experience and knowledge, unless they have been given supervision or instruction concerning use of the appliance by a person responsible for their safety.

SAVE THESE INSTRUCTIONS

- Cautions**
- Use and store the product at a temperature between 32°F (0°C) and 104°F (40°C).
 - Mishandling batteries can cause burn, fire or explosion hazards.
 - Batteries should not be exposed to excessive heat such as bright sunshine or fire.
 - Do not expose the product to extreme cold, heat or direct sunlight. Do not place the product close to a heating source.

- Warning—Strangulation Hazard—Children have STRANGLING in cords. Keep this cord out of the reach of children (more than 3 ft (0.9m) away). Do not remove warning label on the adapter cord.**
- Never place the baby unit(s) inside the baby's crib or playpen. Never cover the baby unit(s) or parent unit with anything such as a towel or a blanket.
 - Other electronic products can cause interference to your parent unit and baby unit. Try installing your baby unit as far away as possible from the following electronic devices: wireless routers, radios, mobile telephones, intercoms, room monitors, televisions, personal computers, kitchen appliances (e.g. microwave ovens) and cordless telephones.

Precautions for users of implanted cardiac pacemakers
Cardiac pacemakers (applies only to digital cordless devices): Wireless Technology Research, LLC (WTR), an independent research entity, led a multidisciplinary evaluation of the interference between portable wireless devices and implanted cardiac pacemakers. Supported by the U.S. Food and Drug Administration, WTR recommends to physicians that:

- Pacemaker patients**
- Should keep wireless devices at least six inches from the pacemaker.
 - Should NOT place wireless devices directly over the pacemaker, such as in a breast pocket, when it is turned ON. WTR's evaluation did not identify any risk to bystanders with pacemakers from other persons using wireless devices.

Electromagnetic fields (EMF)
This VTech product complies with all standards regarding electromagnetic fields (EMF). If handled properly and according to the instructions in this user's manual, the product is safe to be used based on scientific evidence available today.

WHAT'S IN THE BOX

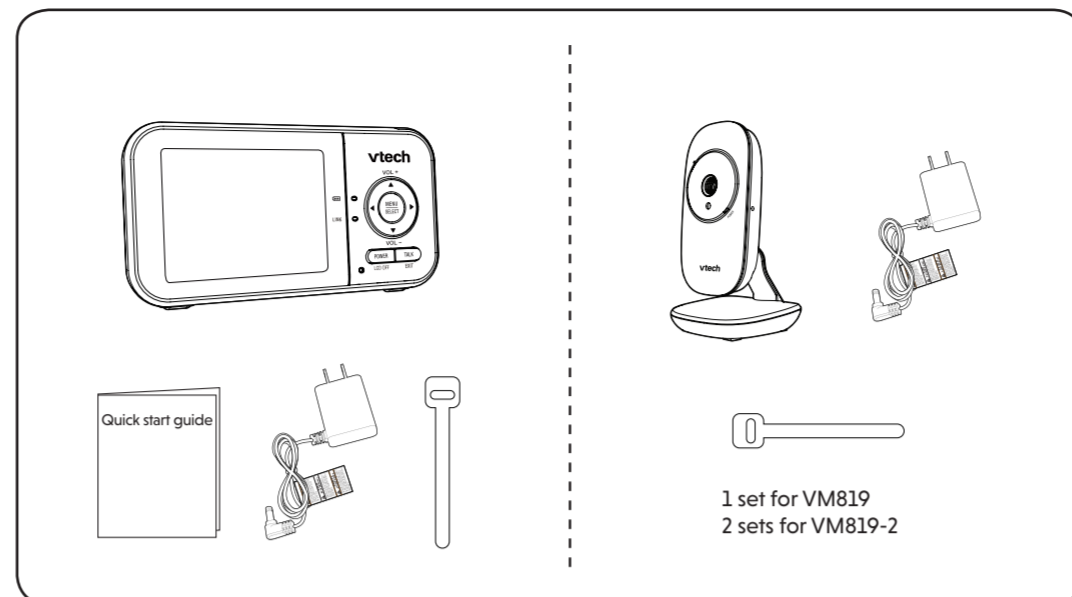

1 set for VM819
2 sets for VM819-2

1 CONNECT THE BABY MONITOR

NOTES

- The rechargeable battery in the parent unit is built-in.
- Use only the power adapters supplied with this product.
- Make sure the parent unit and the baby unit are not connected to an electronically/timer controlled electric outlet.
- Make sure the parent unit, the baby units and the power adapter cords are out of reach of children.

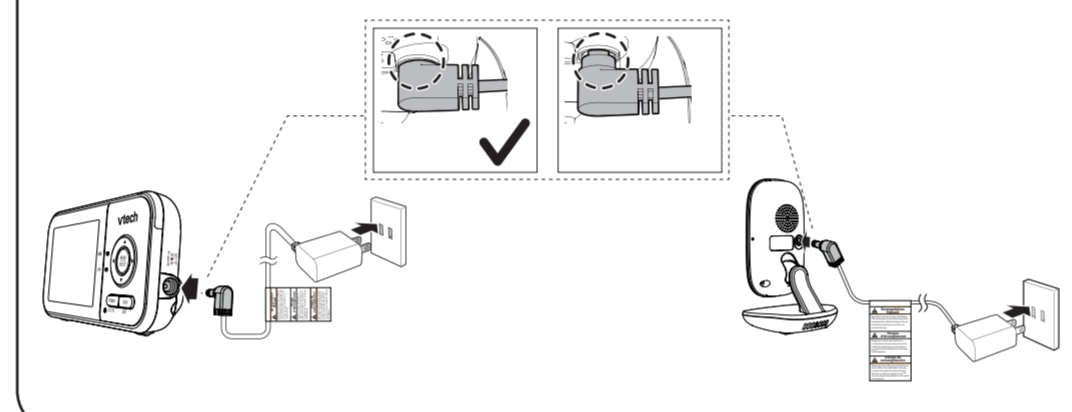

1 CONNECT THE BABY MONITOR (CONT'D)

Charge the parent unit battery

When you have connected and turned on the parent unit, the battery will be charged automatically.

NOTES

- Before using the baby monitor for the first time, charge the parent unit battery for 12 hours. When the parent unit battery is fully charged, the battery icon becomes solid.
- It takes longer to charge the battery when the parent unit is turned on. To shorten the charging time, turn the parent unit off while charging.
- The standby time varies depending on the sensitivity level you set, your actual use and the age of the battery.

The battery icon indicates the battery status (see the following table).

BATTERY INDICATORS	BATTERY STATUS	ACTION
The screen displays . The light flashes.	The battery has very little charge and may be used for only a short time.	Charge without interruption (about 30 minutes).
The battery icon becomes solid .	The battery is fully charged.	To keep the battery charged, connect it to AC power when in use.

2 POWER ON OR OFF THE BABY MONITOR

- Slide the **ON/OFF** switch to power on or off your baby unit.
- Press and hold **POWER** to power on or off your parent unit.

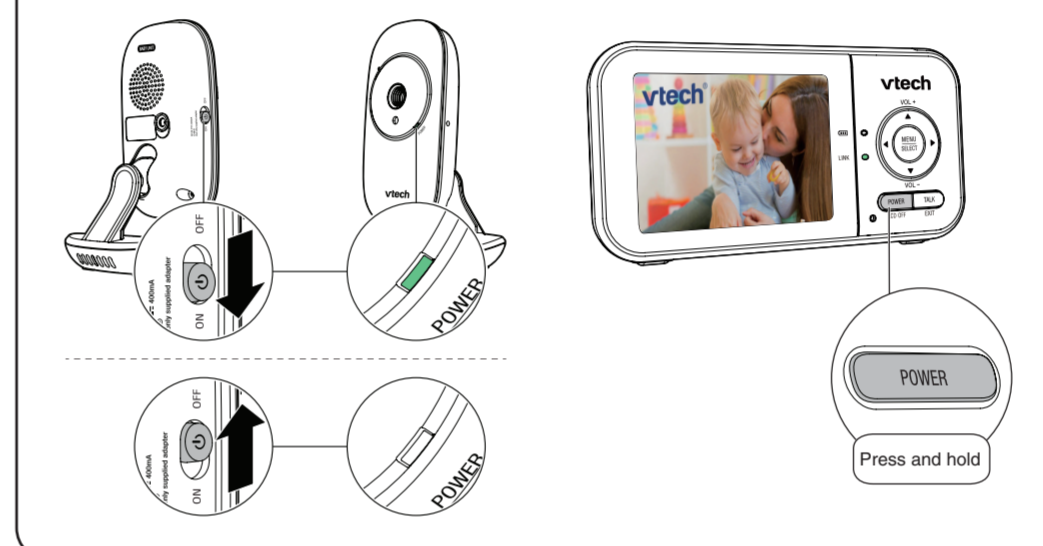

3 POSITIONING THE BABY MONITOR

CAUTION

- Keep the baby unit out of the reach of your baby. Never place or mount the baby unit inside the baby's crib or playpen.

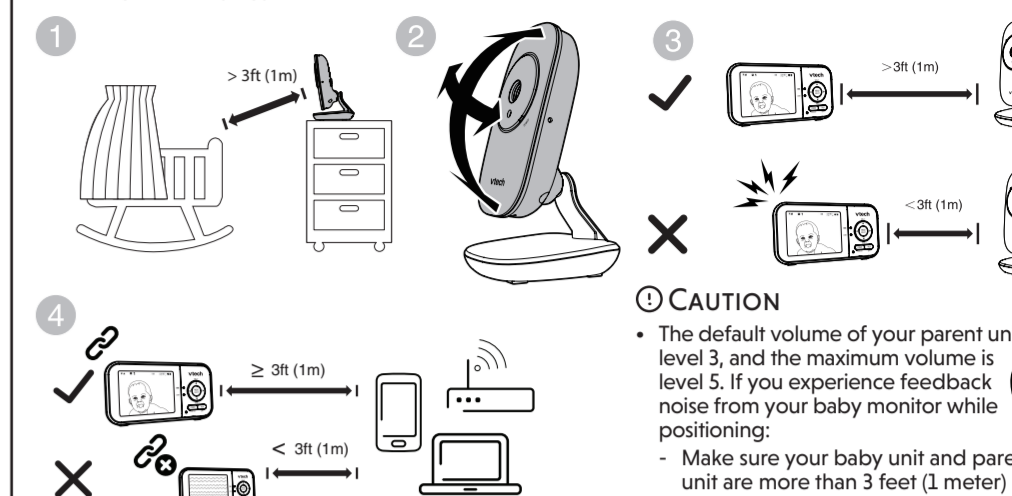

NOTE

- To avoid interference from other electronic devices, place your baby monitor at least 3 feet (1 meter) away from devices such as wireless routers, microwaves, mobile phones and computers.

- CAUTION**
- Please avoid covering the illustrated area to achieve normal range during operation.

4 STATUS CHECK

Once you power on both your baby unit and parent unit, your parent unit displays image from the baby unit, and the **LINK** LED light turns on.

The baby unit's **POWER** LED light turns on.



BASIC OPERATION - PARENT UNIT

Use the menu

Press **MENU** to enter the menu, or save a setting. You can use the parent unit for advanced settings or operations, such as to play or stop the baby unit's lullaby, or to adjust the baby unit's sound sensitivity.

While in the menu:

- Press **Left** or **Right** to scroll among the menu options.
- Press **Up** or **Down** to select an item.
- Press **SELECT** to confirm your selection.
- Press **TALK/EXIT** to exit the menu and return to live view.

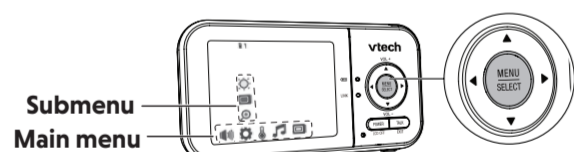

Talk to your baby unit

Press and hold **TALK** and speak to your parent unit. Your voice is transmitted to the baby unit. Release **TALK** when done talking and hear your baby again.

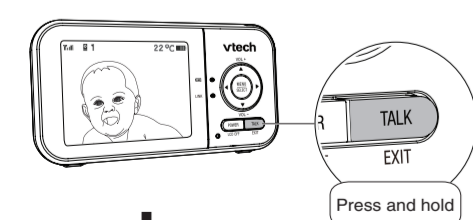

Turn off the screen

Press **POWER/LCD OFF** to switch off the screen. You can still hear sound from the selected baby unit.

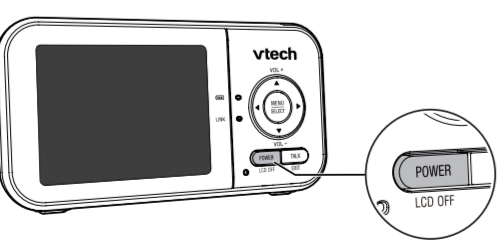

TIP

- Press any keys on the parent unit to turn on the screen again.

Adjust parent unit speaker volume

- Press **▲ VOL+ / ▼ VOL-** to adjust your parent unit speaker volume.

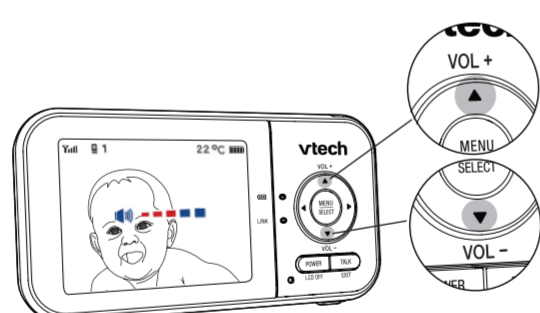

Zoom

- Press **MENU** when in idle mode.
- Choose .
- Press **▲** or **▼** to choose **2X** (Zoom in) or **1X** (Zoom out), then press **SELECT** to confirm your selection.

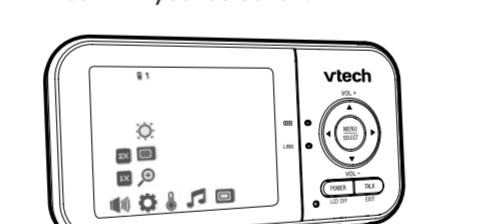

OVERVIEW - PARENT UNIT

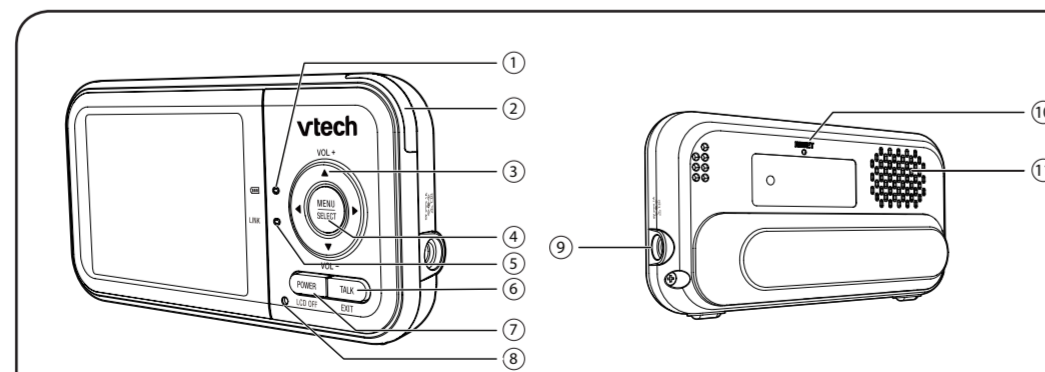

- Battery LED light**
- 3-level sound indicator light**
 - Arrow keys
 - ▲ VOL+ / ▼ VOL-
- MENU/SELECT**
- LINK LED light**
 - On when the parent unit is linked to the baby unit.
 - Flashes when the link to the baby unit is lost.
- TALK/EXIT**
 - Press and hold to talk to the baby unit.
 - While in a submenu, press to exit.
- POWER/LCD OFF**
- Microphone**
- Power jack**
- RESET**
 - Force reboot the parent unit.
- Speaker**

OVERVIEW - BABY UNIT

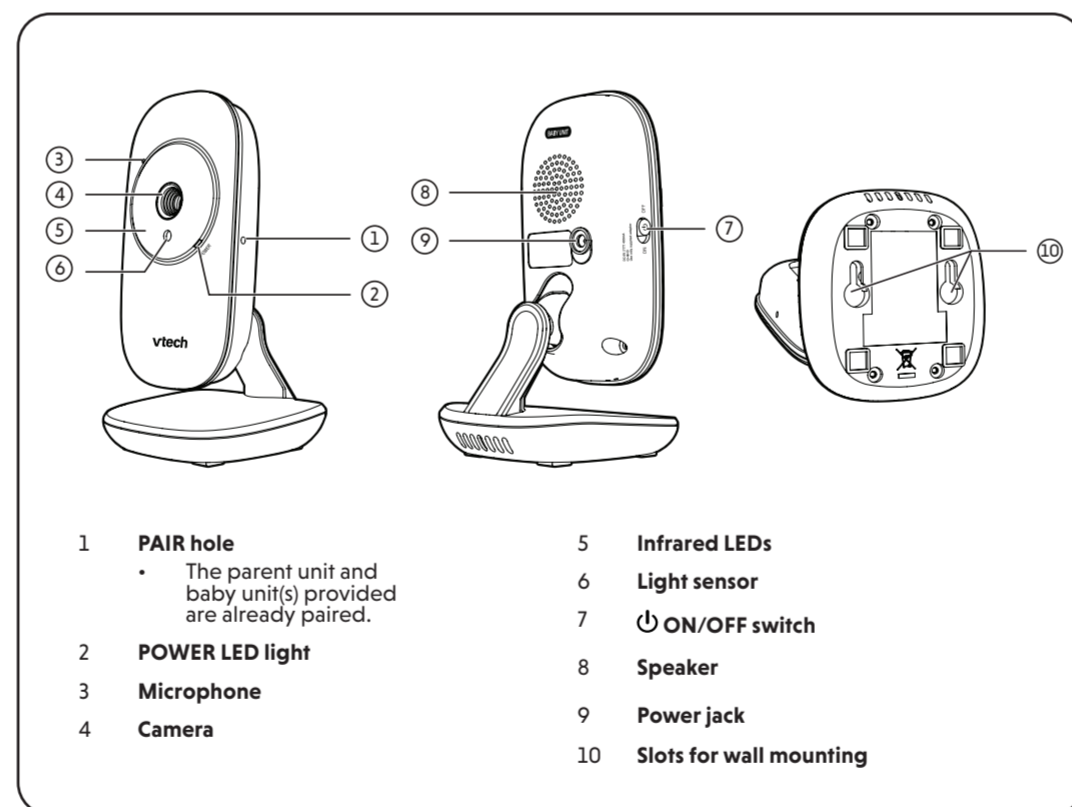

- PAIR hole**
 - The parent unit and baby unit(s) provided are already paired.
- POWER LED light**
- Microphone**
- Camera**
- Infrared LEDs**
- Light sensor**
- ON/OFF switch**
- Speaker**
- Power jack**
- Slots for wall mounting**

NEED HELP?

For operations and guides to help you use your video monitor, and for the latest information and support, check out our online help topics and online FAQs.

Use your smartphone or mobile device to access our online help.

- Go to <https://phones.vtechcanada.com/manuals>; OR
- Scan the QR code on the right. Launch the camera app or QR code scanner app on your smartphone or tablet. Hold the device's camera up to the QR code and frame it. Tap the notification to be redirected to the online help page.
- If the QR code is not clearly displayed, adjust your camera's focus by moving your device closer or further away until it is clear.
- Search for the model - **VM818** or **VM819-2**

You can also call our Customer Support at 1 (800) 267-7377 for help.



CABLE MANAGEMENT

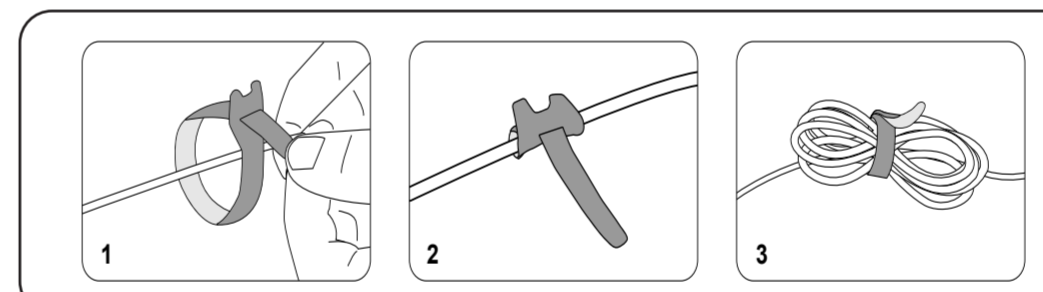

PARENT UNIT ICONS

Status icons

- Connection status**
 - or displays when strong signal strength is detected between the baby unit and the parent unit.
 - or displays when moderate or low signal strength is detected between the baby unit and the parent unit.
- Patrol mode**
 - Displays when the parent unit is in **PATROL** mode (For VM819-2 only).
- Current view status**
 - Displays the baby unit number of the baby unit that is being viewed.
- Zoom**
 - Displays when the current image on the parent unit has zoomed in.
- Night vision**
 - Displays when the baby unit being viewed has activated the night vision feature.
- Talkback**
 - Displays when talking back to the baby units from parent unit.
- Lullaby**
 - Displays when a lullaby is playing.
- Mute alert**
 - Displays when the parent unit speaker volume is set to zero.
 - Displays when the parent unit is talking to the baby unit.
- Real-time temperature**
 - Displays the real-time temperature detected by the baby unit in Fahrenheit (°F) or Celsius (°C) (e.g. **57°F** or **14°C**).
- Battery status**
 - animates when the battery is charging.
 - displays solid when the battery is fully charged.
 - displays when the battery is low and needs charging.

Main menu icons

- | Main menu | Sub-menu | Main menu | Sub-menu |
|-----------------|--|-----------------|--|
| Volume | <ul style="list-style-type: none"> Parent unit speaker volume Adjust the parent unit's speaker volume. | Settings | <ul style="list-style-type: none"> Brightness <ul style="list-style-type: none"> Adjust the parent unit's LCD screen brightness level. Zoom <ul style="list-style-type: none"> Zoom in and out of the video displayed from the baby unit. Temperature <ul style="list-style-type: none"> Turn on/off temperature alert tone. Set the parent unit to beep whenever the room temperature detected by the baby unit falls outside of the set temperature range. Set the minimum/maximum temperature. Set temperature display in Fahrenheit (°F) or Celsius (°C). |
| Settings | <ul style="list-style-type: none"> Screen off timer <ul style="list-style-type: none"> The parent unit screen will turn off after the selected time to save energy. You can still hear your baby while the screen is turned off. VOX (Voice Activated Alert) Sensitivity <ul style="list-style-type: none"> When VOX is selected, the parent unit screen will automatically turn on when detected sounds exceed a set level. You can adjust the baby unit microphone sensitivity level so that the higher the sensitivity level, the more sensitive the baby unit is in detecting sounds for transmitting to the parent unit. For details, see the Sound sensitivity and sound activation section. | | |

☐ PARENT UNIT ICONS (CONT'D)

Main menu icons

Main menu

Lullaby



Lullaby volume

- Adjust the baby unit's speaker volume when playing the lullaby.

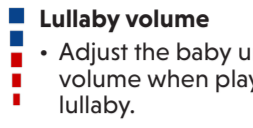

STOP 1 2 3 4

- Select one of the four melodies to play, or stop a lullaby.

Monitoring Mode (For VM819-2 only)

Patrol mode

- Monitor your baby in **PATROL** mode, where the screen will cycle through display videos streamed from all the linked baby unit cameras (For VM819-2 only).



- View the video from your selected baby unit's camera.

Warning icons and messages

Battery low at Parent Unit



The battery is empty and needs to be recharged.

Operation is in progress.



Temperature too high



The temperature detected by the baby unit is higher than the desired temperature alert range.

Temperature too low



The temperature detected by the baby unit is lower than the desired temperature alert range.

No Link to Camera



The parent unit is searching for baby units or the link between the baby unit and the parent unit is lost.

The parent unit is connected to AC power.



Parent Unit Indication Lights

LINK

- On when the parent unit is linked to the baby unit.
- Flashes when the link to the baby unit being viewed is lost.



- On when the parent unit is connected to AC power, or the battery is charging.
- Flashes when the parent unit battery is low and needs charging.
- Off when the parent unit is disconnected from AC power.

🔊 SOUND SENSITIVITY AND SOUND ACTIVATION

Adjust the sound sensitivity of the baby unit

The parent unit screen will turn on only the detected sounds exceed a certain level. Use the parent unit to adjust the microphone sensitivity of your baby unit. The higher the sensitivity level, the more sensitive the baby unit is in detecting sounds that transmit to the parent unit. The VOX sensitivity level is preset to the highest level.

VOX SENSITIVITY LEVEL	Highest	High	Medium	Low	Lowest
DESCRIPTION	The parent unit screen turns on for small sounds, (including background noises) from your baby's room.	The parent unit screen turns on for soft babbling and louder sounds from your baby. It remains off when your baby sleeps soundly.	The parent unit screen turns on for loud babbling and louder sounds from your baby. It remains off when your baby makes soft sounds.	The parent unit screen turns on for crying and louder sounds from your baby. It remains off when your baby makes soft sounds.	The parent unit screen turns on for loud crying or screaming sounds from your baby. It remains off when your baby makes soft sounds.

When select **VOX**, the parent unit screen stays off to save power when the baby unit detects sounds are lower than the set level. Once the baby unit detects sounds that are louder than the selected sound sensitivity level, the parent unit screen turns on automatically. It will then turn off again after 50 seconds if the sounds detected are lower than the set level.

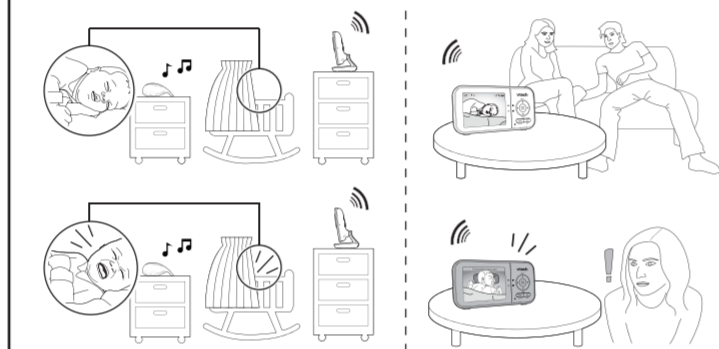

📴 DIM MODE

Dim mode helps you save parent unit power. When your parent unit is not charging, the display will automatically dim after 10 minutes of inactivity if no keys are pressed or alerts are received from the baby unit.

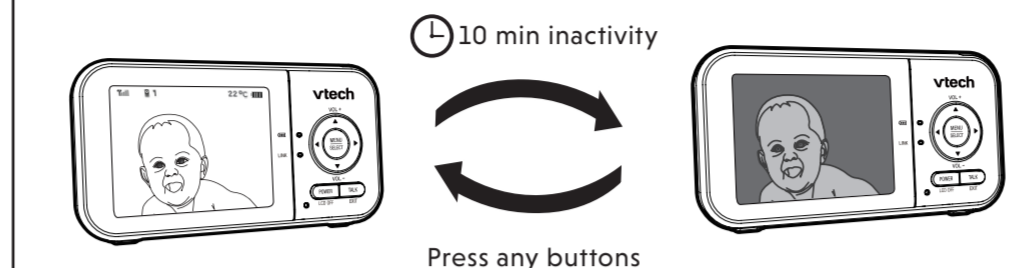

NOTE

- While the screen is dimmed, any keypress or alert message will trigger the screen to return to the preset brightness level. After 10 minutes of inactivity, it will resume to dim mode.

🌙 NIGHT VISION

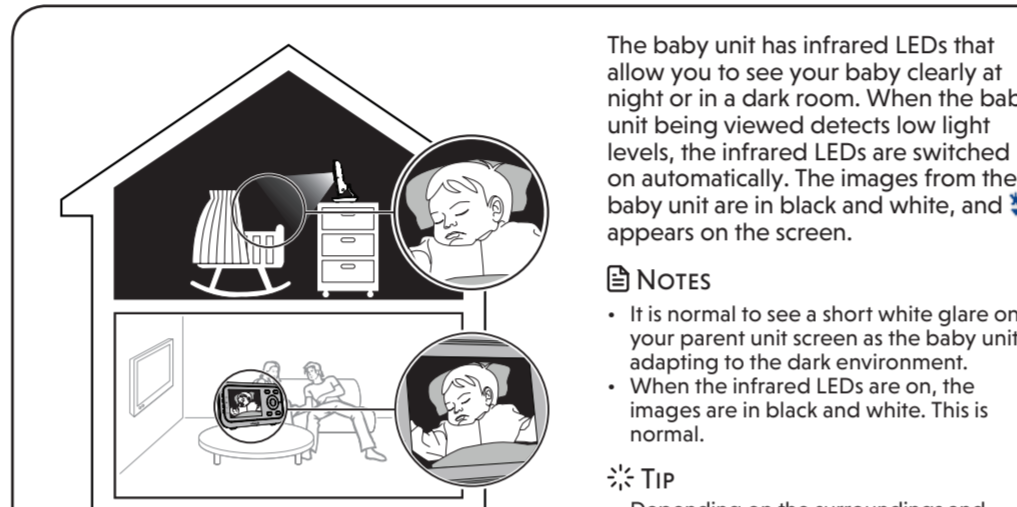

The baby unit has infrared LEDs that allow you to see your baby clearly at night or in a dark room. When the baby unit being viewed detects low light levels, the infrared LEDs are switched on automatically. The images from the baby unit are in black and white, and appears on the screen.

NOTES

- It is normal to see a short white glare on your parent unit screen as the baby unit is adapting to the dark environment.
- When the infrared LEDs are on, the images are in black and white. This is normal.

TIP

- Depending on the surroundings and other interfering factors, like lightings, objects, colors and backgrounds, the display resolution may vary. Adjust the baby unit's angle or place the baby unit at a higher level to prevent glare and blurry display.

📺 FOR VM819-2 ONLY

Status check - Two baby units

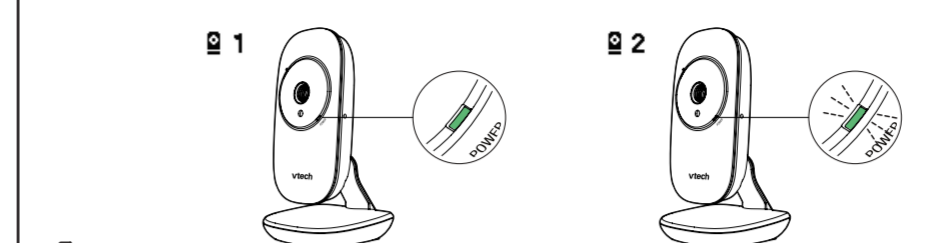

If you are viewing baby unit **1**, the **POWER** LED light of baby unit **1** turns on. As baby unit **2** is not being viewed, its **POWER** LED light flashes.



NOTE



- If you power on only one baby unit, your parent unit may display  and the **LINK** LED light will flash.

Change different views - Patrol

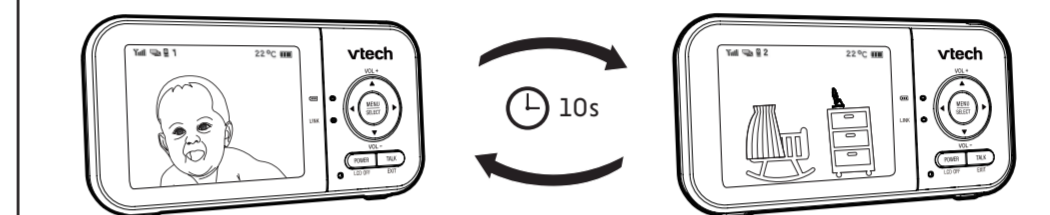
- Press **MENU** when the parent unit is idle.
- Press **◀** or **▶** to choose .
- Press **▼** or **▲** to choose , then press **SELECT** to confirm your selection.



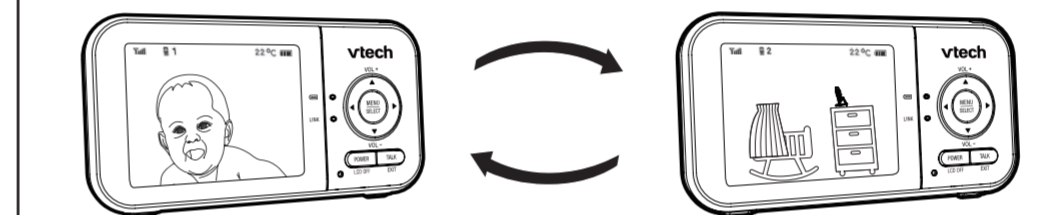

Change different views - Single-cam

- Press **MENU** when the parent unit is idle.
- Press **◀** or **▶** to choose .
- Press **▼** or **▲** to choose between  and , then press **SELECT** to confirm the baby unit you would like to view.



🗋️ FREQUENTLY ASKED QUESTIONS

Below are the questions most frequently asked about the baby monitor.

Why does the baby monitor not respond normally?	Try the following (in the order listed) for common cure: 1. Disconnect the power to the baby units and the parent unit. 2. Wait a few seconds before connecting power back to the baby units and the parent unit. 3. Turn on the baby units and the parent unit. 4. Wait for the parent unit to synchronize with the baby units. Allow up to one minute for this to take place.
Why don't the power-on light of the baby unit and parent unit go on when I switch on the units?	Perhaps the parent unit is not connected to the power. Insert the adapter plug into the parent unit and put the adapter in a wall socket. Then, press and hold POWER to switch on the parent unit and to establish connection with the baby unit. Perhaps the baby unit is not connected to the power. Insert the adapter plug into the baby unit and put the adapter in a wall socket. Then, slide the ON/OFF switch to ON to switch on the baby unit and to establish connection with the parent unit.
Why doesn't my parent unit charge while connected to AC power?	Make sure the power is not controlled by a wall switch. The battery may be degraded through extended use or defective. See Warranty for repair/replacement.
Why is my screen in black and white?	The screen is in black and white during night-time or in a dark room when the night vision feature is activated. This is normal.
Why do I get glare or blurry display on my screen when viewing my baby at night?	During night-time or in a dark room, the surroundings and other interfering factors, like lightings, objects, colors and backgrounds may affect the image quality on your parent unit screen. Adjust the baby unit's angle or place the baby unit at a higher level to prevent glare and blurry display.
Why does the baby monitor produce a feedback noise?	The parent unit and baby units may be too close to each other. • Move the parent unit away from the baby units until the noise stops; OR • Turn down the volume of your parent unit.
Why does the parent unit beep?	The baby units may be out of range. Move the parent unit closer to the baby units (but not less than 3 feet). The parent unit may not have enough charge for the parent unit to perform normally. Charge the battery in the parent unit until the battery icon becomes solid  . The temperature of your baby's room may be too high or too low.
Why does the parent unit react too quickly to other sounds?	The baby unit also picks up other sounds than those of your baby. Adjust the VOX sensitivity level to a lower level or lower the parent unit speaker volume.
Why don't I hear a sound/Why can't I hear my baby cry?	The parent unit speaker volume may be too low. See Adjust parent unit speaker volume to increase the volume.
Why can't I establish a connection? Why is the connection lost every now and then? Why are there sound interruptions?	The baby units may be out of range. Move the parent unit closer to the baby units (but not less than 3 feet). Other electronic products and wireless products may cause interference with your baby monitor. Try installing your baby monitor as far away from these devices as possible. If you power on only one baby unit, your parent unit may display  , and the LINK LED light will flash.

♻️ THE RBRC SEAL

The RBRC seal on the Li-ion battery indicates that VTech Communications, Inc. is voluntarily participating in an industry program to collect and recycle these batteries at the end of their useful lives, when taken out of service within the United States and Canada. The program provides a convenient alternative to placing used Li-ion batteries in the trash or municipal waste, which may be illegal in your area. VTech's participation makes it easy for you to drop off the spent battery at local retailers participating in the program or at authorized VTech product service centers. Please call **1 (800) 8 BATTERY** for information on Li-ion battery recycling and disposal bans/restrictions in your area. VTech's involvement in this program is part of its commitment to protecting our environment and conserving natural resources.

The **RBRC Seal** and **1 (800) 8 BATTERY®** are registered trademarks of Call2recycle, Inc.

FCC AND IC REGULATIONS

FCC Part 15

This equipment has been tested and found to comply with the requirements for a Class B digital device under Part 15 of the Federal Communications Commission (FCC) rules. These requirements are intended to provide reasonable protection against harmful interference in a residential installation. This equipment generates, uses and can radiate radio frequency energy and, if not installed and used in accordance with the instructions, may cause harmful interference to radio communications. However, there is no guarantee that interference will not occur in a particular installation. If this equipment does cause harmful interference to radio or television reception, which can be determined by turning the equipment off and on, the user is encouraged to try to correct the interference by one or more of the following measures:

- Reorient or relocate the receiving antenna.
- Increase the separation between the equipment and receiver.
- Connect the equipment into an outlet on a circuit different from that to which the receiver is connected.
- Consult the dealer or an experienced radio/TV technician for help.

WARNING: Changes or modifications to this equipment not expressly approved by the party responsible for compliance could void the user's authority to operate the equipment.

This device complies with Part 15 of the FCC rules. Operation is subject to the following two conditions: (1) this device may not cause harmful interference, and (2) this device must accept any interference received, including interference that may cause undesired operation.

To ensure safety of users, the FCC has established criteria for the amount of radio frequency energy that can be safely absorbed by a user or bystander according to the intended usage of the product. This product has been tested and found to comply with the FCC criteria. The baby unit shall be installed and used such that parts of all persons' body are maintained at a distance of approximately 8 in (20 cm) or more. The transmitter and antenna of the parent unit shall be held at least 1 in (2.5 cm) from your face.

This Class B digital apparatus complies with Canadian requirement: CANI ICES-3 (B)/NMB-3(B)

Industry Canada

This device contains licence-exempt transmitter(s)/receiver(s) that comply with Innovation, Science and Economic Development Canada's licence-exempt RSS(s). Operation is subject to the following two conditions: (1) This device may not cause interference. (2) This device must accept any interference, including interference that may cause undesired operation of the device.

The term "IC:" before the certification/registration number only signifies that the Industry Canada technical specifications were met. This product meets the applicable Innovation, Science and Economic Development Canada technical specifications.

RF radiation exposure statement

The baby unit complies with FCC RF radiation exposure limits set forth for an uncontrolled environment. The baby unit should be installed and operated with a minimum distance of 8 in (20 cm) between the baby unit and all persons' body. Use of other accessories may not ensure compliance with FCC RF exposure guidelines. This equipment complies also with Industry Canada R55-102 with respect to Canada's Health Code 6 for Exposure of Humans to RF Fields.

LIMITED WARRANTY

What does this limited warranty cover?

The manufacturer of this VTech Product warrants to the holder of a valid proof of purchase ("Consumer" or "you") that the Product and all accessories provided in the sales package ("Product") are free from defects in material and workmanship, pursuant to the following terms and conditions, when installed and used normally and in accordance with the Product operating instructions. This limited warranty extends only to the Consumer for Products purchased and used in the United States of America and Canada.

What will VTech do if the Product is not free from defects in materials and workmanship during the limited warranty period ("Materially Defective Product")?

During the limited warranty period, VTech's authorized service representative will repair or replace at VTech's option, without charge, a Materially Defective Product. If we repair the Product, we may use new or refurbished replacement parts. If we choose to replace the Product, we may replace it with a new or refurbished Product of the same or similar design. We will retain defective parts, modules, or equipment. Repair or replacement of the Product, at VTech's option, is your exclusive remedy. VTech will return the repaired or replacement Products to you in working condition. You should expect the repair or replacement to take approximately 30 days.

How long is the limited warranty period?

The limited warranty period for the Product extends for ONE (1) YEAR from the date of purchase. If VTech repairs or replaces a Materially Defective Product under the terms of this limited warranty, this limited warranty also applies to the repaired or replacement Product for a period of either (a) 90 days from the date the repaired or replacement Product is shipped to you or (b) the time remaining on the original one-year warranty, whichever is longer.

What is not covered by this limited warranty?

This limited warranty does not cover:

- Product that has been subjected to misuse, accident, shipping or other physical damage, improper installation, abnormal operation or handling, neglect, inundation, fire, water or other liquid intrusion; or
- Product that has been damaged due to repair, alteration or modification by anyone other than an authorized service representative of VTech; or
- Product to the extent that the problem experienced is caused by signal conditions, network reliability, or cable or antenna systems; or
- Product to the extent that the problem is caused by use with non-VTech accessories; or
- Product whose warranty/quality stickers, product serial number plates or electronic serial numbers have been removed, altered or rendered illegible; or
- Product purchased, used, serviced, or shipped for repair from outside the United States of America or Canada, or used for commercial or institutional purposes (including but not limited to Products used for rental purposes); or
- Product returned without a valid proof of purchase (see item 2 below); or
- Charges for installation or set up, adjustment of customer controls, and installation or repair of systems outside the unit.

How do you get warranty service?

To obtain warranty service in the USA, please visit our website at www.vtechphones.com or call 1 (800) 595-9511. In Canada, go to www.vtechcanada.com or call 1 (800) 267-7377.

NOTE: Before calling for service, please review the user's manual - a check of the Product's controls and features may save you a service call.

Except as provided by applicable law, you assume the risk of loss or damage during transit and transportation and are responsible for delivery or handling charges incurred in the transport of the Product(s) to the service location. VTech will return repaired or replaced Product under this limited warranty. Transportation, delivery or handling charges are prepaid. VTech assumes no risk for damage or loss of the Product in transit. If the Product failure is not covered by this limited warranty, or proof of purchase does not meet the terms of this limited warranty, VTech will notify you and will request that you authorize the cost of repair prior to any further repair activity. You must pay for the cost of repair and return shipping costs for the repair of Products that are not covered by this limited warranty.

What must you return with the Product to get warranty service?

- Return the entire original package and contents including the Product to the VTech service location along with a description of the malfunction or difficulty; and
- Include a "valid proof of purchase" (sales receipt) identifying the Product purchased (Product model) and the date of purchase or receipt; and
- Provide your name, complete and correct mailing address, and telephone number.

Other limitations

This warranty is the complete and exclusive agreement between you and VTech. It supersedes all other written or oral communications related to this Product. VTech provides no other warranties for this Product. The warranty exclusively describes all of VTech's responsibilities regarding the Product. There are no other express warranties. No one is authorized to make modifications to this limited warranty and you should not rely on any such modification. State/Provincial Law Rights: This warranty gives you specific legal rights, and you may also have other rights, which vary from state to state or province to province.

Limitations: Implied warranties, including those of fitness for a particular purpose and merchantability (an unwritten warranty that the Product is fit for ordinary use) are limited to one year from the date of purchase. Some states/provinces do not allow limitations on how long an implied warranty lasts, so the above limitation may not apply to you. In no event shall VTech be liable for any indirect, special, incidental, consequential, or similar damages (including, but not limited to lost profits or revenue, inability to use the Product or other associated equipment, the cost of substitute equipment, and claims by third parties) resulting from the use of this Product. Some states/provinces do not allow the exclusion or limitation of incidental or consequential damages, so the above limitation or exclusion may not apply to you.

Please retain your original sales receipt as proof of purchase.

🔩 MOUNT THE BABY UNIT ON DRY WALL (OPTIONAL)

Items to purchase

You will need to purchase the following items separately to mount your baby unit:

- 2 screws
- 2 anchors

NOTE

- The types of screws and anchors you need depend on the composition of the wall.

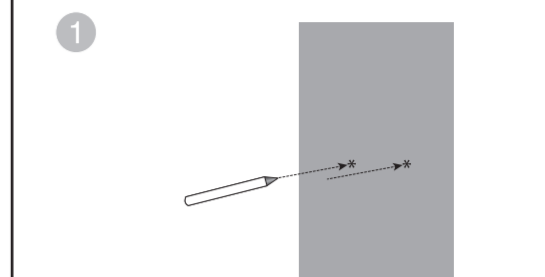

NOTE

- Check for reception strength and camera angle before drilling the holes.

Use a pencil to mark two holes in parallel. Make sure they are the same distance apart as the wall mount holes on the baby unit.

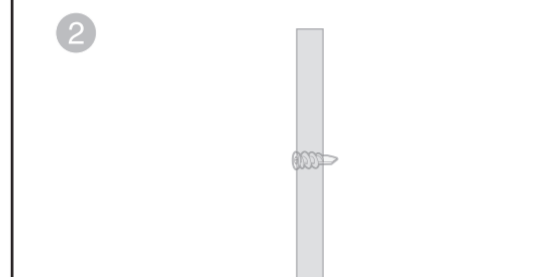

Drill two holes in the wall (7/32 inch drill bit). If you drill the holes into a stud, go to step 3.

-OR-

If you drill the holes into an object other than a stud, insert the wall anchors into the holes. Tap gently on the ends with a hammer until the wall anchors are flush with the wall.

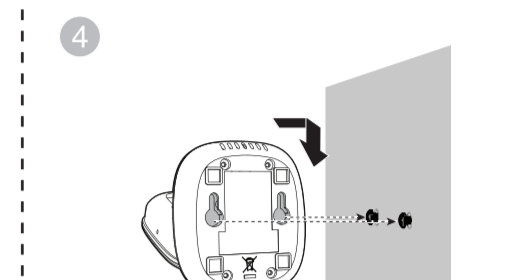
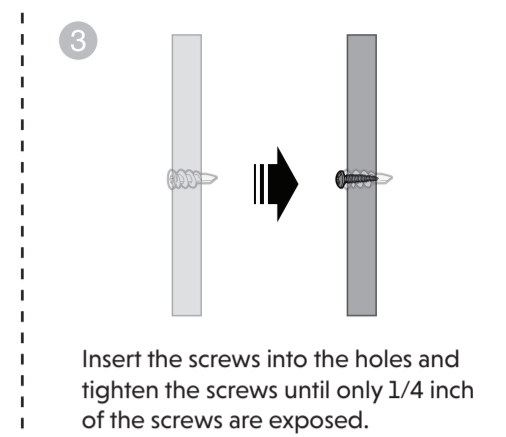

Align the wall mount holes on the baby unit with the screws on the wall. Slide the baby unit down until it locks into place.

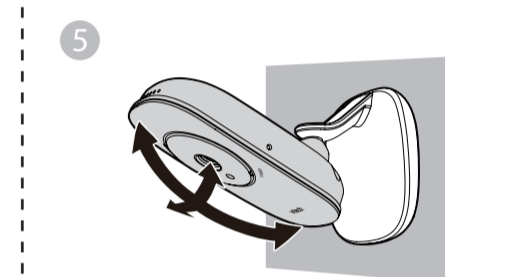

Adjust the camera angle.